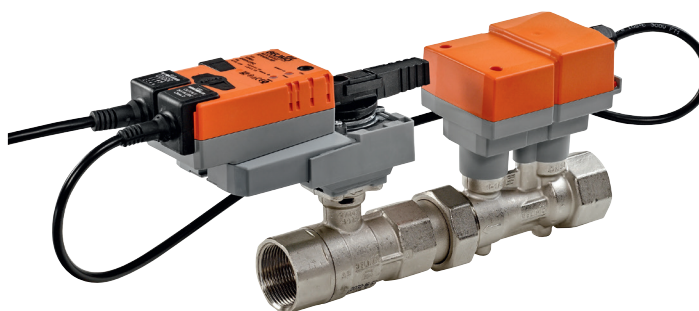

Characterised control valve with sensor-operated flow control, 2-way, Internal thread, PN 25 (EPIV)

- Nominal voltage AC/DC 24 V
- Control modulating, communicative
- For closed cold and warm water systems
- For modulating control of air-handling and heating systems on the water side
- Communication via Belimo MP-Bus or conventional control
- Conversion of active sensor signals and switching contacts

**Type overview**

Type	DN [ ]	Rp ["]	V'nom [ l/s]	V'nom [ l/min]	V'nom [ m³/h]	kvs theor. [ m³/h]	PN [ ]
<b>EP015R+MP</b>	15	1/2	0.35	21	1.26	2.9	25
<b>EP020R+MP</b>	20	3/4	0.65	39	2.34	4.9	25
<b>EP025R+MP</b>	25	1	1.15	69	4.14	8.6	25
<b>EP032R+MP</b>	32	1 1/4	1.8	108	6.48	14.2	25
<b>EP040R+MP</b>	40	1 1/2	2.5	150	9	21.3	25
<b>EP050R+MP</b>	50	2	4.8	288	17.28	32.0	25

kvs theor.: Theoretical kvs value for pressure drop calculation

**Technical data**

<b>Electrical data</b>	Nominal voltage	AC/DC 24 V	
	Nominal voltage frequency	50/60 Hz	
	Nominal voltage range	AC 19.2...28.8 V / DC 21.6...28.8 V	
	Power consumption in operation	3.5 W (DN 15...25) 4.5 W (DN 32...50)	
	Power consumption in rest position	1.3 W (DN 15...25) 1.4 W (DN 32...50)	
	Power consumption for wire sizing	6 VA (DN 15...25) 7 VA (DN 32...50)	
	Connection supply / control	Cable 1 m, 4 x 0.75 mm <sup>2</sup>	
	Parallel operation	Yes (note the performance data)	
	<b>Functional data</b>	Torque motor	5Nm (DN 15...25) 10Nm (DN 32...40) 20Nm (DN 50)
		Communicative control	MP-Bus
Operating range Y		2...10 V	
Input Impedance		100 kΩ	
Operating range Y variable		Start point 0.5...24 V End point 8.5...32 V	
Options positioning signal		Modulating (DC 0...32 V)	
Position feedback U		2...10 V	
Position feedback U note		Max. 1 mA	
Position feedback U variable		Start point 0.5...8 V End point 2...10 V	
Sound power level Motor		45 dB(A)	
Adjustable flow rate V'max		30...100% of Vnom	
Control accuracy		±5% (of 25...100% V'nom) @ 20°C / Glycol 0% vol.	
Control accuracy note		±10% (of 25...100% V'nom) @ -10...120°C / Glycol 0...50% vol.	
Min. controllable flow		1% of V'nom	
Fluid	Cold and warm water, water with glycol up to max. 50% vol.		
Fluid temperature	-10...120°C		
Fluid temperature note	At a fluid temperature of -10...2°C, a stem heating or a valve neck extension is recommended.		

## Technical data

<b>Functional data</b>	Close-off pressure $\Delta p_s$	1400 kPa
	Differential pressure $\Delta p_{max}$	350 kPa
	Differential pressure note	200 kPa for low-noise operation
	Flow characteristic	equal percentage (VDI/VDE 2178), optimised in the opening range (switchable to linear)
	Leakage rate	air-bubble tight, leakage rate A (EN 12266-1)
	Pipe connection	Internal thread according to ISO 7-1
	Installation position	upright to horizontal (in relation to the stem)
	Servicing	maintenance-free
	Manual override	with push-button, can be locked
<b>Flow measurement</b>	Measuring principle	Ultrasonic volumetric flow measurement
	Measuring accuracy flow	$\pm 2\%$ (of 25...100% V'nom) @ 20°C / Glycol 0% vol.
	Measuring accuracy flow note	$\pm 6\%$ (of 25...100% V'nom) @ -10...120°C / Glycol 0...50% vol.
	Min. flow measurement	0.5% of V'nom
<b>Safety</b>	Protection class IEC/EN	III Safety Extra-Low Voltage (SELV)
	Degree of protection IEC/EN	IP54
	EMC	CE according to 2014/30/EU
	Mode of operation	Type 1
	Rated impulse voltage supply / control	0.8 kV
	Control pollution degree	3
	Ambient temperature	-30...50°C
	Storage temperature	-40...80°C
	Ambient humidity	Max. 95% r.H., non-condensing
<b>Materials</b>	Flow measuring pipe	Brass body nickel-plated
	Closing element	Stainless steel
	Stem seal	EPDM O-ring

## Safety notes



- This device has been designed for use in stationary heating, ventilation and air-conditioning systems and must not be used outside the specified field of application, especially in aircraft or in any other airborne means of transport.
- Outdoor application: only possible in case that no (sea) water, snow, ice, insolation or aggressive gases interfere directly with the actuator and that is ensured that the ambient conditions remain at any time within the thresholds according to the data sheet.
- Only authorised specialists may carry out installation. All applicable legal or institutional installation regulations must be complied during installation.
- The device contains electrical and electronic components and must not be disposed of as household refuse. All locally valid regulations and requirements must be observed.

## Product features

**Mode of operation** The HVAC performance device is comprised of three components: characterised control valve (CCV), measuring pipe with volumetric flow sensor and the actuator itself. The adjusted maximum flow (V'max) is assigned to the maximum positioning signal (typically 10 V / 100%). The final controlling device can be controlled communicative or analogue. The fluid is detected by the sensor in the measuring pipe and is applied as the flow value. The measured value is balanced with the setpoint. The actuator corrects the deviation by changing the valve position. The angle of rotation  $\alpha$  varies according to the differential pressure through the final controlling element (see volumetric flow curves).

## Product features

### Flow characteristic

Flow rate curves

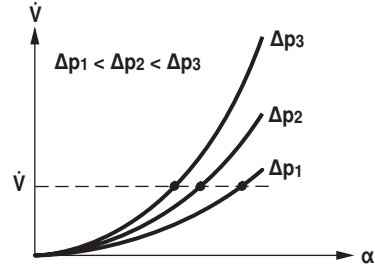

### Transmission behaviour HE

Heat exchanger transmission behaviour

Depending on the construction, temperature spread, fluid characteristics and hydraulic circuit, the power  $Q$  is not proportional to the water volumetric flow  $\dot{V}$  (Curve 1). With the classical type of temperature control, an attempt is made to maintain the control signal  $Y$  proportional to the power  $Q$  (Curve 2). This is achieved by means of an equal-percentage valve characteristic curve (Curve 3).

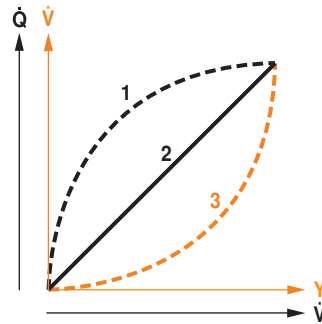

Product features

Control characteristics

The fluid velocity is measured in the measuring component (sensor electronics) and converted to a flow rate signal.  
 The positioning signal Y corresponds to the power Q via the exchanger, the volumetric flow is regulated in the EPIV. The control signal Y is converted into an equal-percentage characteristic curve and provided with the V'max value as the new reference variable w. The momentary control deviation forms the positioning signal Y1 for the actuator.  
 The specially configured control parameters in connection with the precise flow rate sensor ensure a stable quality of control. They are however not suitable for rapid control processes, i.e. for domestic water control.  
 U5 displays the measured volumetric flow as voltage (factory setting). As an alternative, U5 can be used for displaying the valve opening angle. It is always in reference to the respective V'nom, i.e. if V'max is e.g. 50% of V'nom, then Y = 10 V, U5 = 5 V.

1. Standard equal percentage  $V_{max} = V_{nom} / 2$  effect  $V_{max} < V_{nom}$

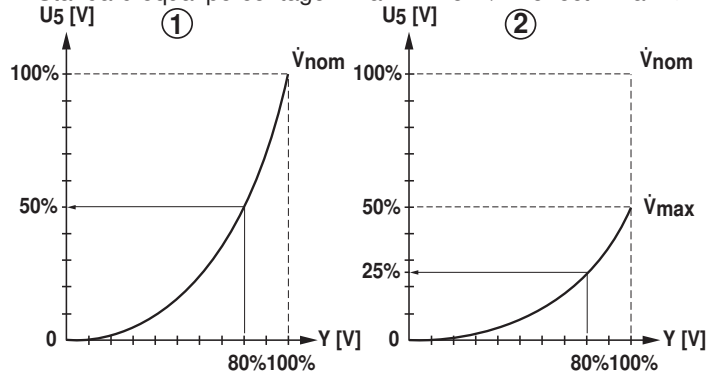

Block diagram

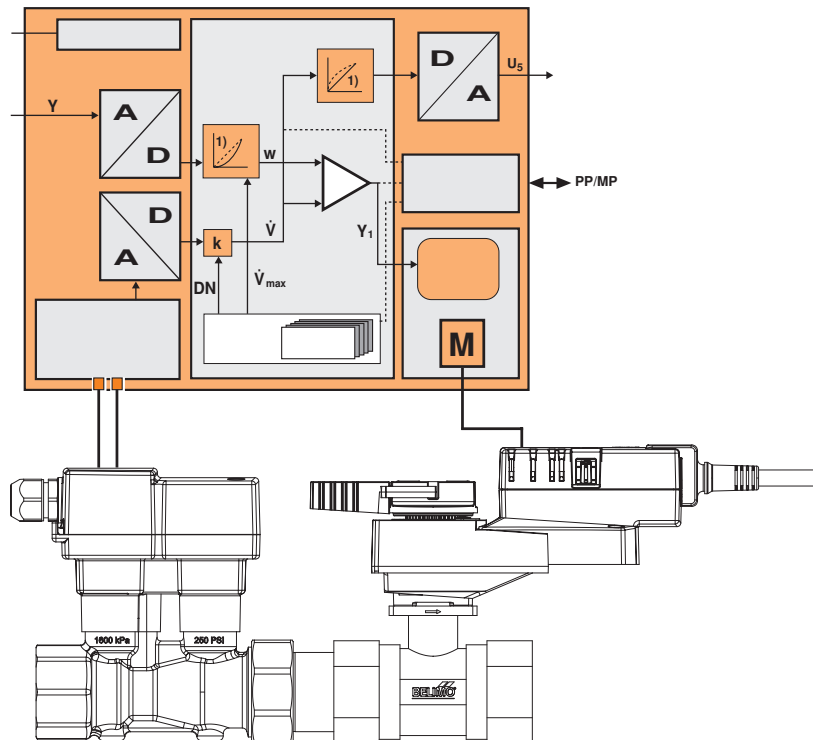

## Product features

**Definition** Flow control  
 $V'_{nom}$  is the maximum possible flow.

$V'_{max}$  is the maximum flow rate which has been set with the greatest positioning signal.  $V'_{max}$  can be set between 30% and 100% of  $V'_{nom}$ .

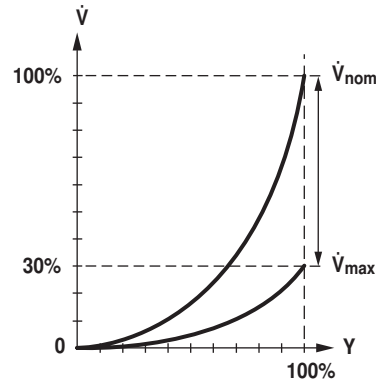

**Creep flow suppression** Given the very low flow speed in the opening point, this can no longer be measured by the sensor within the required tolerance. This range is overridden electronically.

### Opening valve

The valve remains closed until the volumetric flow required by the positioning signal  $Y$  corresponds to 1% of  $V'_{nom}$ . The control along the valve characteristic curve is active after this value has been exceeded.

### Closing valve

The control along the valve characteristic curve is active up to the required flow rate of 1% of  $V'_{nom}$ . Once the level falls below this value, the flow rate is maintained at 1% of  $V'_{nom}$ . If the level falls below the flow rate of 0.5% of  $V'_{nom}$  required by the reference variable  $Y$ , then the valve will close.

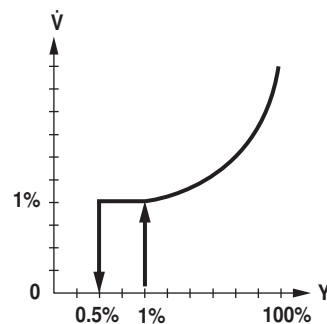

**Converter for sensors** Connection option for a sensor (active sensor or switching contact). The MP actuator serves as an analogue/digital converter for the transmission of the sensor signal via MP-Bus to the higher level system.

**Parametrisable actuators** The factory settings cover the most common applications. Single parameters can be modified with the Belimo Service Tools MFT-P or ZTH EU.

**Positioning signal inversion** This can be inverted in cases of control with an analogue positioning signal. The inversion causes the reversal of the standard behaviour, i.e. at a positioning signal of 0%, regulation is to  $V'_{max}$ , and the valve is closed at a positioning signal of 100%.

**Hydraulic balancing** With the Belimo tools, the maximum flow rate (equivalent to 100% requirement) can be adjusted on-site, simply and reliably, in a few steps. If the device is integrated in the management system, then the balancing can be handled directly by the management system.

**Manual override** Manual override with push-button possible (the gear is disengaged for as long as the button is pressed or remains locked).

**High functional reliability** The actuator is overload protected, requires no limit switches and automatically stops when the end stop is reached.

Accessories

	Description	Type
<b>Gateways</b>	Gateway MP zu BACnet MS/TP	UK24BAC
	Gateway MP to Modbus RTU	UK24MOD
	Gateway MP to KNX	UK24EIB
<b>Electrical accessories</b>	<b>Description</b>	<b>Type</b>
	Connection cable 5 m, A: RJ11 6/4 ZTH EU, B: 6-pin for connection to service socket	ZK1-GEN
	Connection cable 5 m, A: RJ11 6/4 ZTH EU, B: free wire end for connection to MP/PP terminal	ZK2-GEN
	Connecting board MP-Bus for wiring boxes EXT-WR-FP...MP MP-Bus power supply for MP actuators	ZFP2-MP ZN230-24MP
<b>Mechanical accessories</b>	<b>Description</b>	<b>Type</b>
	Pipe connector for ball valve DN 15 Rp 1/2"	ZR2315
	Pipe connector for ball valve DN 20 Rp 3/4"	ZR2320
	Pipe connector for ball valve DN 25 Rp 1"	ZR2325
	Pipe connector for ball valve DN 32 Rp 1 1/4"	ZR2332
	Pipe connector for ball valve DN 40 Rp 1 1/2"	ZR2340
	Pipe connector for ball valve DN 50 Rp 2"	ZR2350
Valve neck extension for ball valve DN15...50	ZR-EXT-01	
<b>Service Tools</b>	<b>Description</b>	<b>Type</b>
	Service Tool, with ZIP-USB function, for parametrisable and communicative Belimo actuators / VAV controller and HVAC performance devices	ZTH EU
	Belimo PC-Tool, Software for adjustments and diagnostics Adapter for Service-Tool ZTH	MFT-P MFT-C

Electrical installation



Notes

- Connection via safety isolating transformer.
- Parallel connection of other actuators possible. Observe the performance data.

Wiring diagrams

AC/DC 24 V, modulating

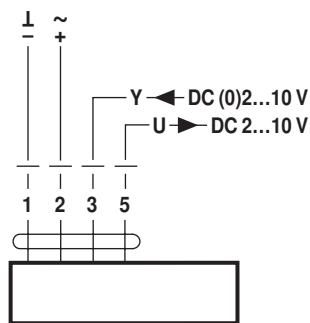

Cable colours:

- 1 = black
- 2 = red
- 3 = white
- 5 = orange

Operation on the MP-Bus

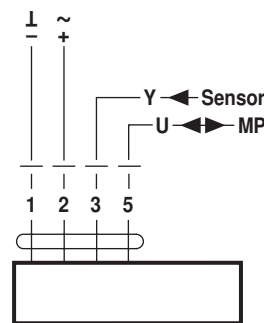

Cable colours:

- 1 = black
- 2 = red
- 3 = white
- 5 = orange

**Functions**

**Functions when operated on MP-Bus**

Connection on the MP-Bus

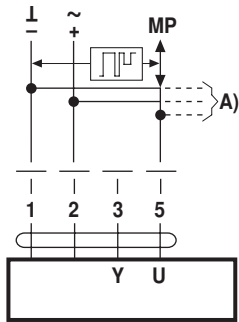

A) additional MP-Bus nodes (max. 8)

MP-Bus Network topology

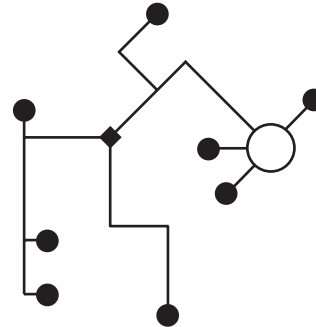

There are no restrictions for the network topology (star, ring, tree or mixed forms are permitted). Supply and communication in one and the same 3-wire cable

- no shielding or twisting necessary
- no terminating resistors required

Connection of active sensors

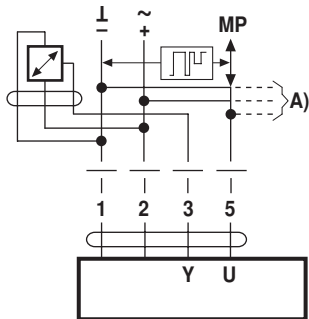

A) additional MP-Bus nodes (max. 8)

- Supply AC/DC 24 V
- Output signal DC 0...10 V (max. DC 0...32 V)
- Resolution 30 mV

Connection of external switching contact

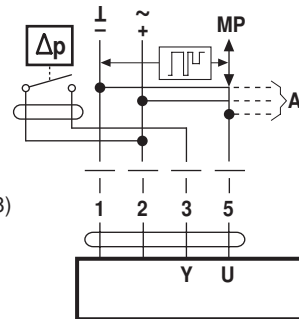

A) additional MP-Bus nodes (max. 8)

- Switching current 16 mA @ 24 V
- Start point of the operating range must be parametrised on the MP actuator as  $\geq 0.5$  V

**Functions for devices with specific parameters (Parametrisation necessary)**

Override control and limiting with AC 24 V with relay contacts

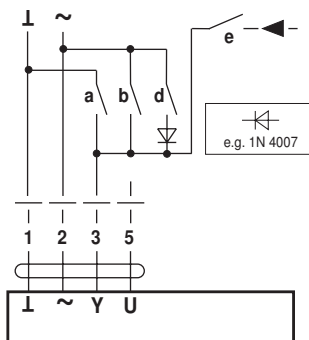

	a	b	d	e
Close				
$\dot{V}_{max}$				
Open				
Y				

Override control and limiting with DC 24 V with relay contacts

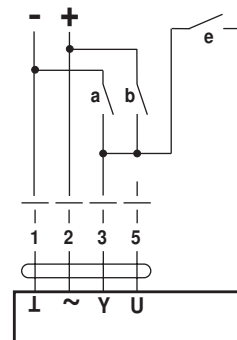

	a	b	d	e
Close				
$\dot{V}_{max}$				
Y				

Control 3-point

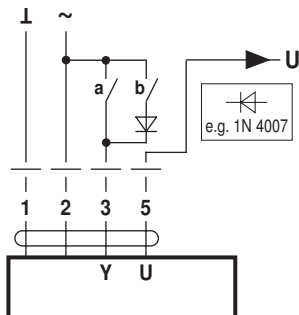

Position control:  $90^\circ = 100s$   
Flow control:  $V_{max} = 100s$

## Operating controls and indicators

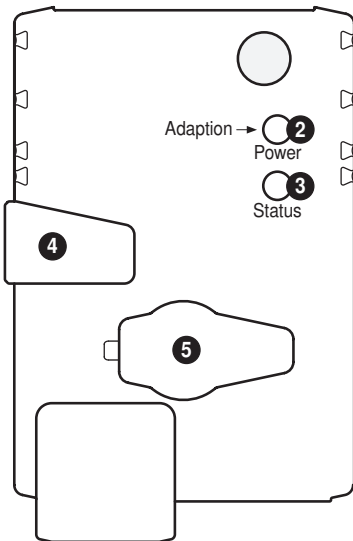

### 2 Push-button and LED display green

Off: No power supply or malfunction  
 On: In operation  
 Press button: Triggers angle of rotation adaptation, followed by standard mode

### 3 Push-button and LED display yellow

Off: Standard mode without MP bus  
 Flickering: MP communication active  
 On: Adaptation or synchronising process active  
 Press button: Confirmation of the addressing

### 4 Gear disengagement button

Press button: Gear disengages, motor stops, manual override possible  
 Release button: Gear engages, synchronisation starts, followed by standard mode

### 5 Service plug

For connecting parameterisation and service tools

### Check power supply connection

2 Off and 3 On Possible wiring error in power supply

## Installation notes

**Recommended installation positions** The ball valve can be installed upright to horizontal. The ball valve may not be installed in a hanging position, i.e. with the stem pointing downwards.

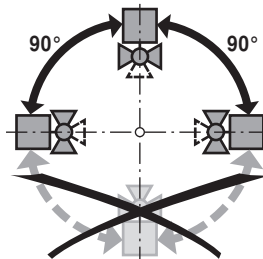

**Mounting position in the return** Installation in the return is recommended.

**Water quality requirements** The water quality requirements specified in VDI 2035 must be adhered to. Belimo valves are regulating devices. For the valves to function correctly in the long term, they must be kept free from particle debris (e.g. welding beads during installation work). The installation of a suitable strainer is recommended.

**Servicing** Ball valves, rotary actuators and sensors are maintenance-free. Before any service work on the final controlling device is carried out, it is essential to isolate the rotary actuator from the power supply (by unplugging the electrical cable if necessary). Any pumps in the part of the piping system concerned must also be switched off and the appropriate slide valves closed (allow all components to cool down first if necessary and always reduce the system pressure to ambient pressure level). The system must not be returned to service until the ball valve and the rotary actuator have been correctly reassembled in accordance with the instructions and the pipeline has been refilled by professionally trained personnel.

**Flow direction** The direction of flow, specified by an arrow on the housing, is to be complied with, since otherwise the flow rate will be measured incorrectly.



**Installation notes**

**Inlet section** In order to achieve the specified measuring accuracy, a flow-calming section or inflow section in the direction of the flow is to be provided upstream from the flow sensor. Its dimensions should be at least 5x DN.

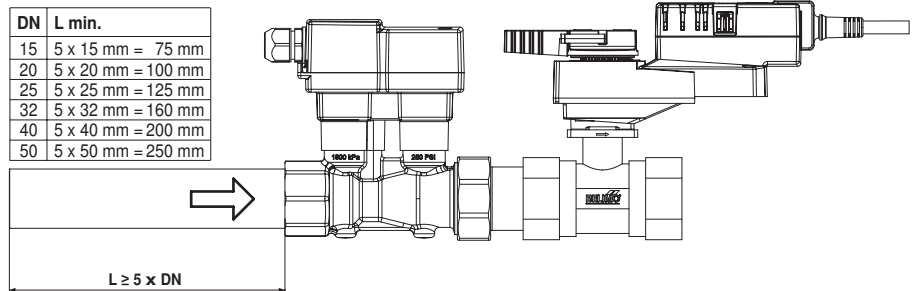

**Split installation** The valve-actuator combination may be mounted separately from the flow sensor. The direction of flow must be observed.

**General notes**

**Valve selection** The valve is determined using the maximum required flow rate V'max. A calculation of the kvs value is not required.  
 V'max = 30...100% of V'nom  
 If no hydraulic data are available, then the same valve DN can be selected as the heat exchanger nominal diameter.

**Minimum differential pressure (pressure drop)** The minimum required differential pressure (pressure drop through the valve) for achieving the desired volumetric flow V'max can be calculated with the aid of the theoretical kvs value (see type overview) and the below-mentioned formula. The calculated value is dependent on the required maximum volumetric flow V'max. Higher differential pressures are compensated for automatically by the valve.

Formula

$$\Delta p_{min} = 100 \times \left( \frac{\dot{V}_{max}}{k_{vs \text{ theor.}}} \right)^2$$

$\Delta p_{min}$ : kPa
$\dot{V}_{max}$ : m <sup>3</sup> /h
$k_{vs \text{ theor.}}$ : m <sup>3</sup> /h

Example (DN25 with the desired maximum flow rate = 50% V'nom)  
 EP025R+MP  
 kvs theor. = 8.6 m<sup>3</sup>/h  
 V'nom = 69 l/min  
 50% \* 69 l/min = 34.5 l/min = 2.07 m<sup>3</sup>/h

$$\Delta p_{min} = 100 \times \left( \frac{\dot{V}_{max}}{k_{vs \text{ theor.}}} \right)^2 = 100 \times \left( \frac{2.07 \text{ m}^3/\text{h}}{8.6 \text{ m}^3/\text{h}} \right)^2 = 6 \text{ kPa}$$

**Behaviour with sensor failure** In case of a flow sensor error, the EPIV will switch from flow control to position control. Once the error disappears, the EPIV will switch back to the normal control setting.

Service

**Service Tools connection** The actuator can be parametrised by ZTH EU via the service socket. For an extended parametrisation the PC tool can be connected.

Connection ZTH EU / PC-Tool

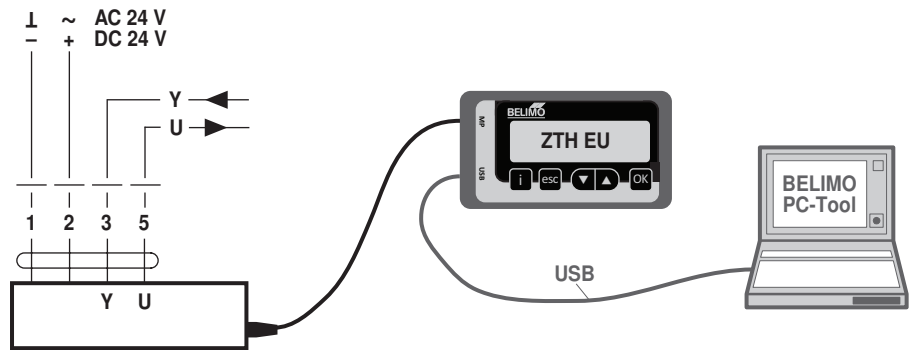

Dimensions / Weight

Dimensional drawings

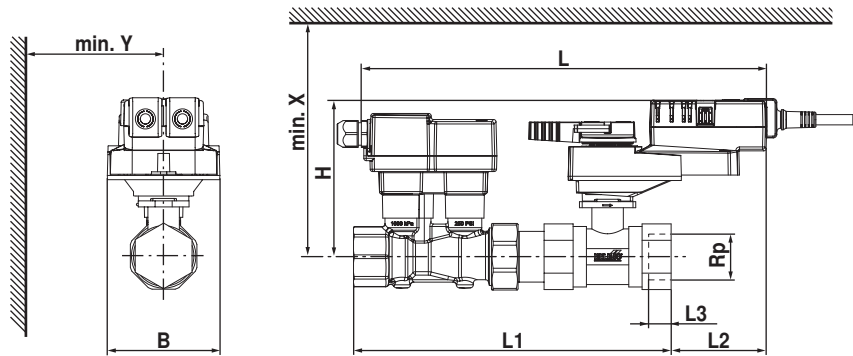

Type	DN [ ]	Rp ["]	L [ mm]	L1 [ mm]	L2 [ mm]	L3 [ mm]	B [ mm]	H [ mm]	X [ mm]	Y [ mm]	Weight
EP015R+MP	15	1/2	275	192	81	13	75	125	195	77	1.4 kg
EP020R+MP	20	3/4	291	211	75	14	75	125	195	77	1.7 kg
EP025R+MP	25	1	295	230	71	16	75	127	197	77	2.3 kg
EP032R+MP	32	1 1/4	323	255	68	19	85	131	201	77	2.6 kg
EP040R+MP	40	1 1/2	325	267	65	19	85	141	211	77	3.4 kg
EP050R+MP	50	2	343	288	69	22	95	142	212	77	5.1 kg

Further documentation

- Overview MP Cooperation Partners
- Tool connections
- Introduction to MP-Bus Technology
- General notes for project planning